



Liqui-Cel® 10 x 28 SS Sanitary Membrane Contactor
Assembly & Disassembly Instructions



www.liqui-cel.com

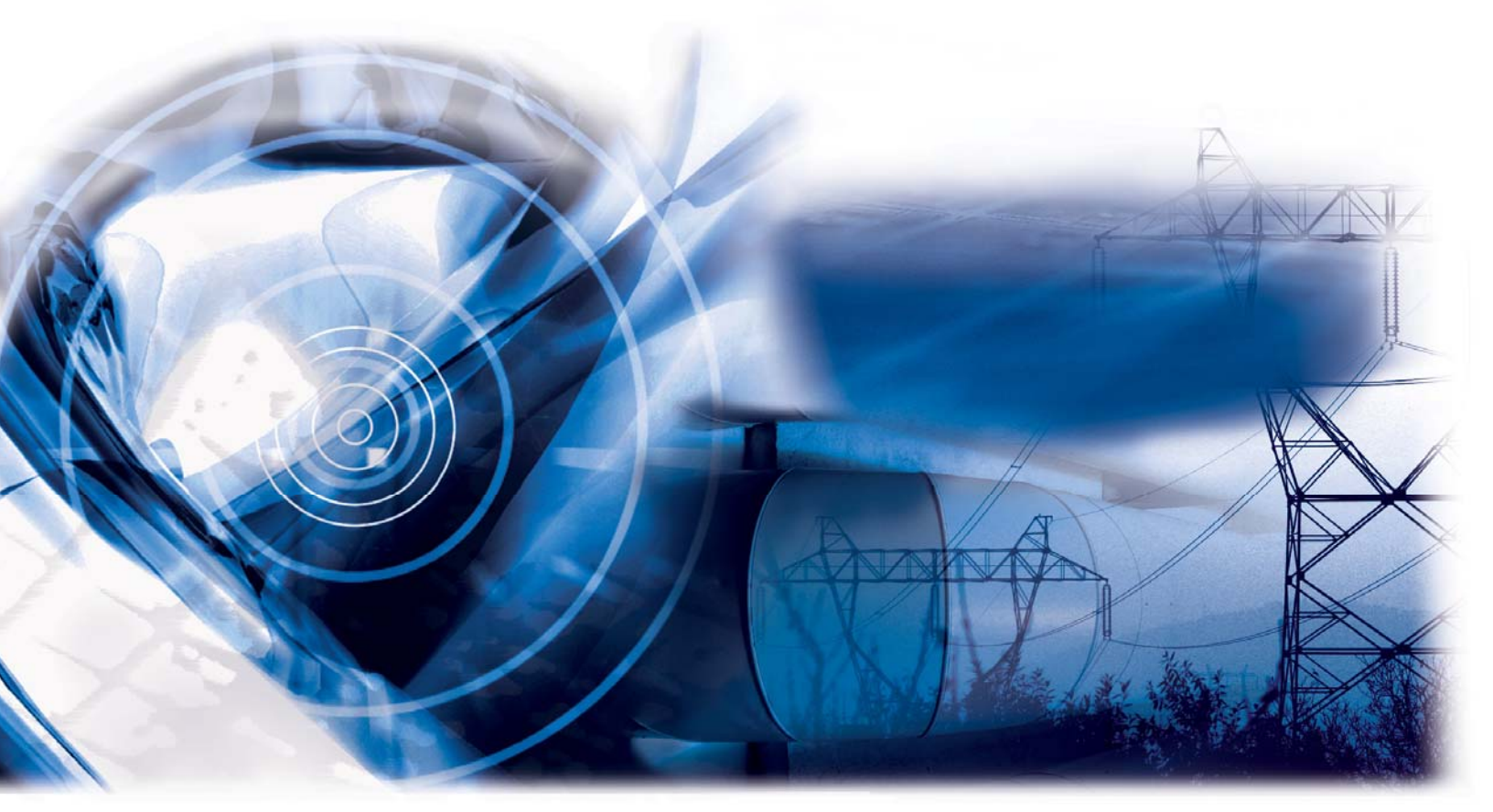

TABLE OF CONTENTS

• Assembly Parts	1
• Part Orientation	1
• Assembly Tools	2
• End Cap Removal	4
• Cartridge Insertion	5
• End Cap Preparation / Installation	8
• Center Seal Tightening	10
• Pressure Test	10

THE INFORMATION CONTAINED HEREIN AND SELLER'S PRODUCTS ARE PROVIDED "AS IS" WITHOUT WARRANTY OF ANY KIND, EITHER EXPRESSED OR IMPLIED, INCLUDING, BUT NOT LIMITED TO, THE IMPLIED WARRANTIES OF MERCHANTABILITY, FITNESS FOR ANY PARTICULAR PURPOSE OR USE, OR NON-INFRINGEMENT OF INTELLECTUAL PROPERTY. IN NO EVENT SHALL SELLER BE LIABLE FOR ANY SPECIAL, INCIDENTAL, INDIRECT, OR CONSEQUENTIAL DAMAGES OF ANY KIND, OR ANY DAMAGES WHATSOEVER RESULTING FROM THE USE OF INFORMATION CONTAINED HEREIN AND SELLER'S PRODUCTS.

Assembly Parts

- a) **O-rings (4)**
 - Inner O-ring:** This 7.5mm O-ring is used to seal the cartridge into the housing. It is located on the liquid side or shellside.
 - Outer O- Ring:** This 6.9mm O-ring is used to seal the cartridge into the end cap. It is located on the gas side or lumenside.
- b) **Lock ring (2)** An elastomeric ring used to position the inner shellside O-ring.
- c) **Center Seal (2)** Seals the center tube of cartridge and center nozzle of the end cap.
- d) **Center Seal Washer (2)** This washer protects the Center Seal during tightening.
- e) **Center Seal Nut (1)** This nut is used to tighten the Center Seal onto the center nozzle.

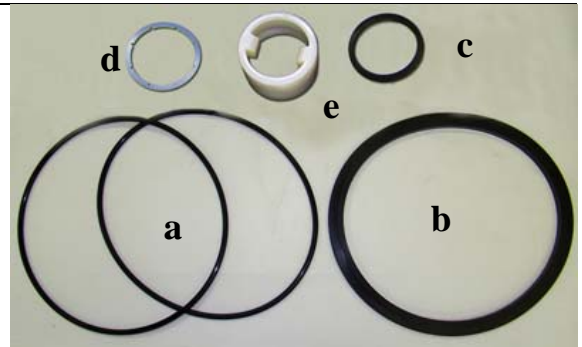

Parts shown represent one end cap only.

Part Orientation

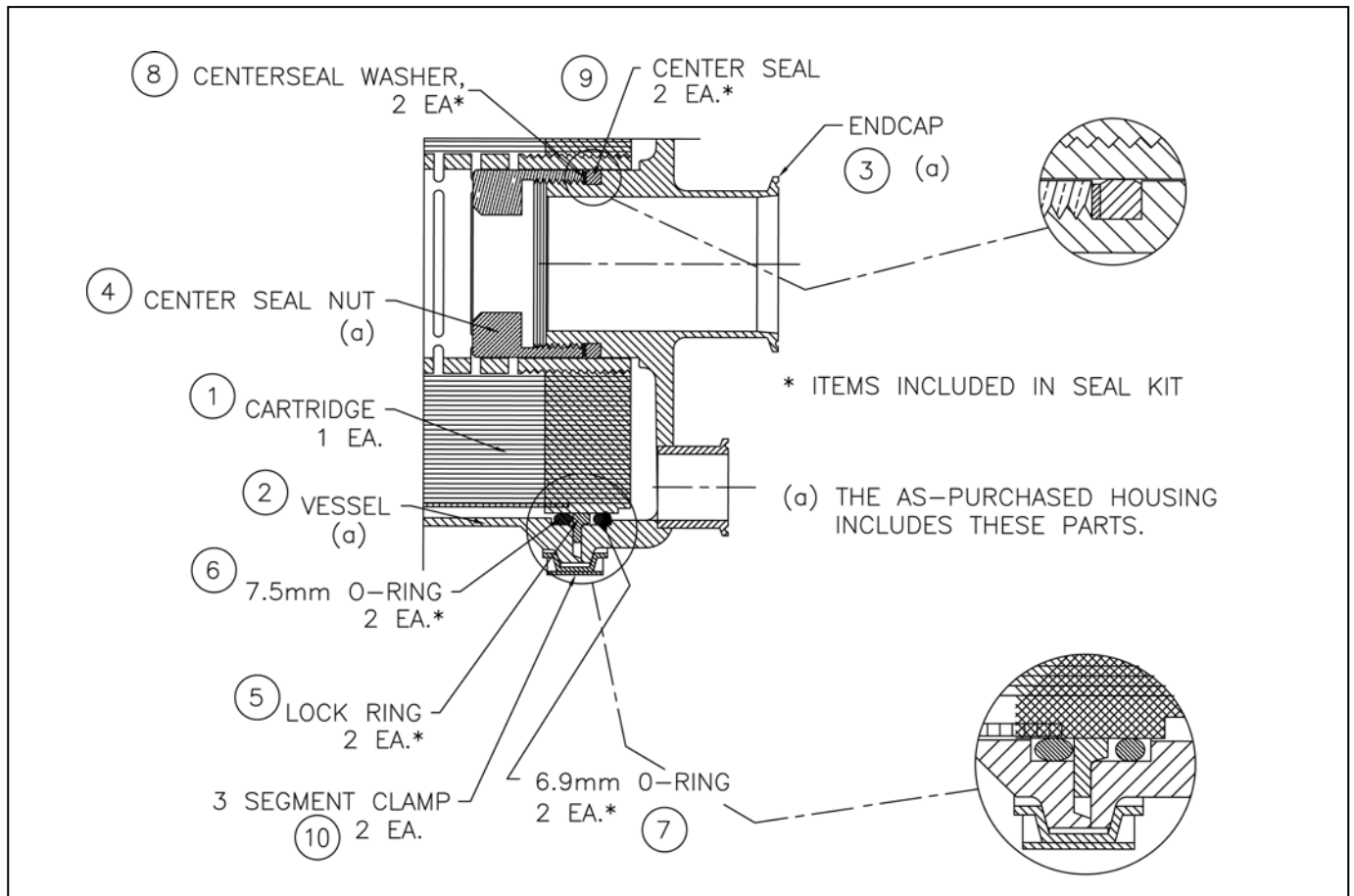

Assembly Tools

10 x 28 Change-Out Tools

- Rubber Mallet** Used to tap T-handle during inner O-ring insertion
- T-Handle** Used to insert inner (shellside) O-ring during assembly
- O-Ring Pick** Used to remove the inner (shellside) O-ring during disassembly
- Center Seal Tool** Used to loosen / tighten *Center Seal Nut*
- Torque Wrench** Used to set a specific torque on the *Center Seal nut* (not included with kit)



- Cartridge Alignment Tool** Used to align cartridge with housing

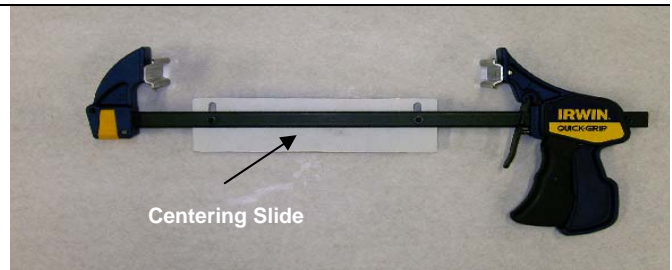

10X28 End Cap Assembly Tools

A complete assembly tool kit will include the following:

- End Cap Assembly Tool** Used to evenly pull the end caps onto the vessel
- Assembly Rods** Used to join the Assembly Brackets
- Assembly Brackets** Angle brackets that fit onto and support the end caps of the module.
- Connecting Rods (set of 4) Brackets** Threaded rods that are used to connect the Assembly at each end of the contactor. Used for final installation of the end caps.

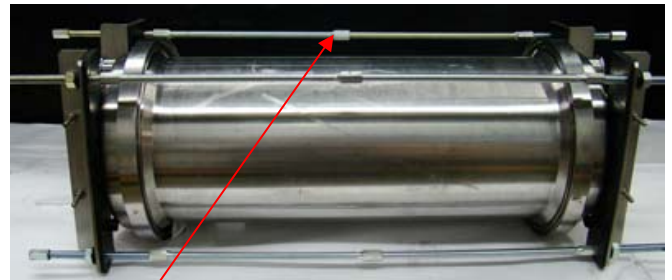

Completed Assembly Kit

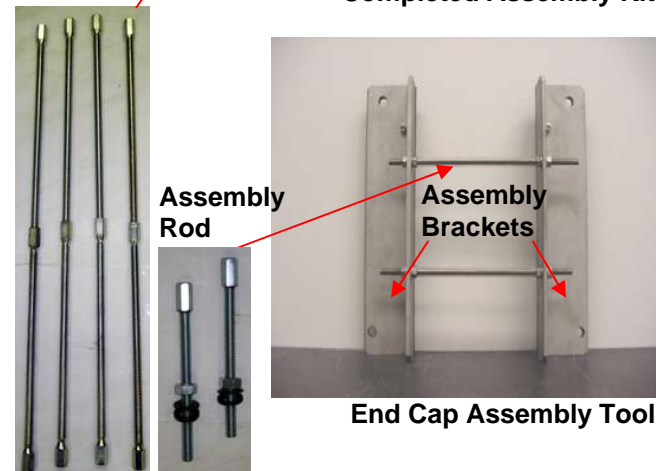

Connecting Rods

10x28 End Cap Assembly Tools (continued)

End Cap Assembly Tool (Back view)

Rubber pads are adhered to the Assembly Brackets to protect the surface of the end cap.

Support knobs attached to the Assembly Brackets are used to support the bracket on the end cap perimeter.

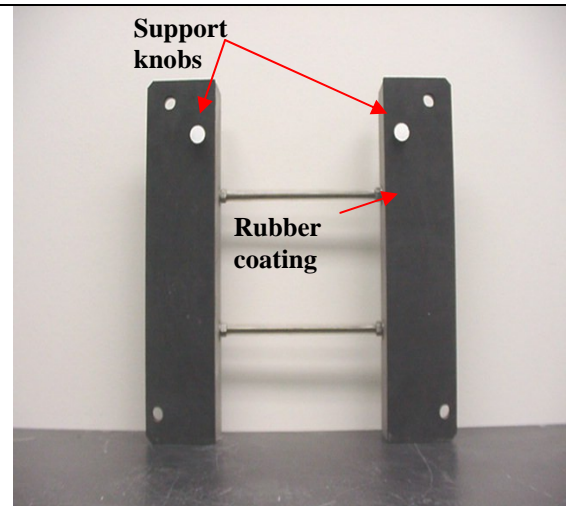

The end cap assembly tool is packaged and shipped unassembled. Upon receipt, assemble as shown. Typically, hand tightening the nuts is adequate.

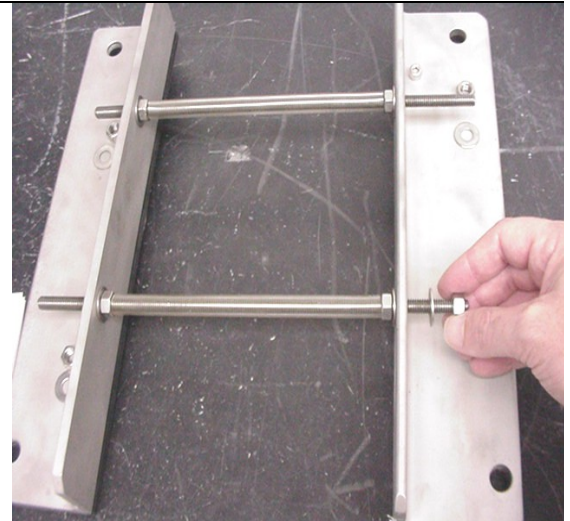

The equipment illustrated above is required for the assembly or disassembly of a 10X28 Liqui-Cel Membrane Contactor with sanitary connections that will be assembled in a 316L SS Housing.

End Cap Removal

- Secure the contactor to prevent the unit from rolling. Use caution when securing the contactor to prevent the housing from being damaged.
- Place the contactor horizontally. Insert the center seal tool into the center nozzle. Turn the tool until you feel the notch in the tool mesh with the nubs of the center unit. Slowly loosen the center seal nut by turning in a clockwise direction 2 rotations.
- Loosen the V-Band clamp. Remove the nut from the V-band clamp and remove the clamp from the assembly.



- Using a permanent marker place 2 small alignment marks, one on the housing and one on the end cap. This will allow the end cap to be reassembled in the same position.
- Move end cap up and down, and left and right until it becomes loose. Remove end cap and set aside. It may also be necessary to insert a prybar or screwdriver into the space between the end cap and housing to separate the two pieces.
- **EXTREME CAUTION** must be used to ensure that the epoxy surface of the contactor is not damaged. Be sure to keep the end cap matched up with same end of the housing it was removed from to allow proper realignment upon reassembly.
- Remove all seal elements between the cartridge and the housing. It will be necessary to use the O-ring pick to remove the inner (shellside) O-ring. Discard used O-rings.

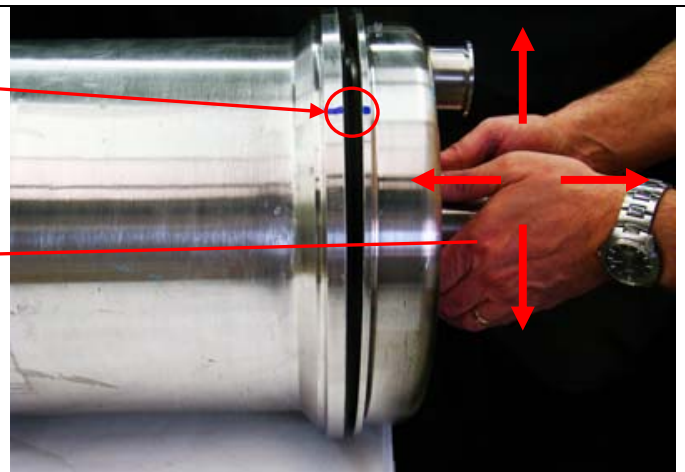

Repeat all of the above steps for each end of the contactor.

Cartridge Insertion

- Carefully clean the sealing surfaces of the housing and the cartridge.
- Slide the cartridge into the housing leaving the epoxy equally exposed on each end.
- EXTREME CAUTION must be used to ensure that the epoxy surface of the contactor is not damaged. Be sure to keep the end cap with same end of the housing to allow proper realignment upon reassembly.
- Review the **Assembly Parts** and **Part Orientation** drawing in this guide to become familiar with the part location and terminology.



- Check to be sure that the cartridge is centered in the housing. Look at and feel both ends to ensure proper alignment.
- Measure both ends using a ruler to assure the membrane cartridge is centered in the housing.



- Loosen the wing nuts on the centering slide on the cartridge alignment tool.
- Clamp the cartridge alignment tool on one end of the housing.
- Move slide until it is flush against the face of the cartridge and tighten wing nuts.
- Check to make sure the cartridge is still centered. Use a ruler if necessary.
- If adjusting is necessary, it must be done now before O-rings are inserted completely.



Cartridge Insertion (continued)

- Starting at the end opposite the alignment tool, place the 7.5mm shell-side O-ring around the outside of the cartridge.
- Lift the cartridge slightly and use the T-handle insertion tool to press the O-ring into the space between the housing wall and the epoxy sealing surface of the contactor at the 6 o'clock position (see diagram 1).
- Recheck cartridge alignment.
- Once the alignment is acceptable, continue to set the O-rings in the 12 o'clock, 3 o'clock and 9 o'clock positions using the T-handle insertion tool.

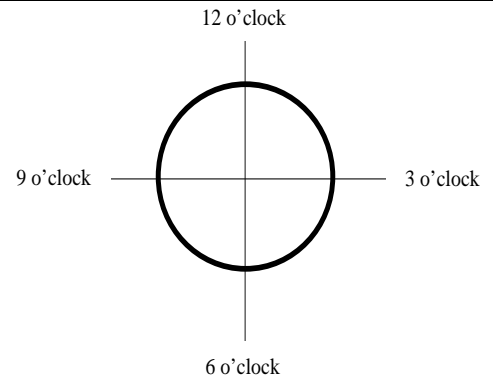

Diagram 1

- Use the T-Handle insertion tool to press in the remaining O-ring sections. When inserting the O-rings, it is best to always divide each section of un-inserted O-ring in half and press in the middle section. See the photograph below, for an example.
- When the 7.5 mm O-ring is completely inserted, remove the cartridge alignment tool.
- Repeat the same process on opposite end of cartridge.



NOTE: If the O-ring is ever pinched or cut it MUST be removed and discarded.

After the O-ring has been inserted where these arrows point, use the insertion tool as pictured. Carefully tap with rubber mallet to complete O-ring insertion.

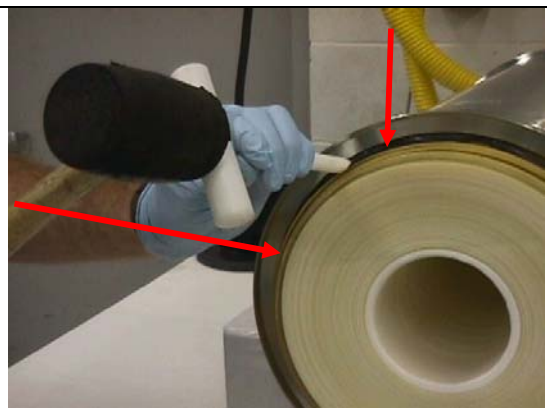

-
- Place the lock ring around the outside of the cartridge.
(See *Assembly Parts "b"* on page 1).

NOTE: The flat side of the lock ring should be facing inward.



-
- Place the outer O-ring (6.9 mm) on the lumen epoxy sealing surface. If the O-ring appears to be rolled or twisted, please adjust the position so the O-ring sits flat on the epoxy. (See *Assembly Parts "a"* on page 1).
 - Repeat these steps on the opposite end of the cartridge.

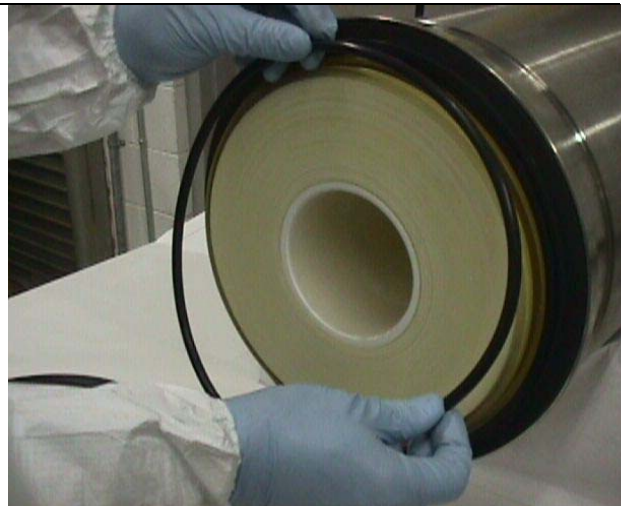

End Cap Preparation / Installation

- Remove the outer Seal Nut and set aside.
- Remove the Center seal and washer and discard.
- Inspect and clean the sealing surface of both end caps.
- Place the Center Seal (*Assembly Part c* on page 1) on the center nozzle. Press it down and over the threads until it rests flat against the lip on center post.
- Place the Center Seal Washer (thinner washer, *Assembly Part d* on page 1) over the center nozzle and slide it past the nozzle threads until it lays flat against the Center Seal. The Center Seal Washer **MUST** be inserted completely past the center nozzle threads and lay flat against the center seal.
- Screw the Center Seal Nut onto the nozzle. Once it touches the washer, loosen one turn.

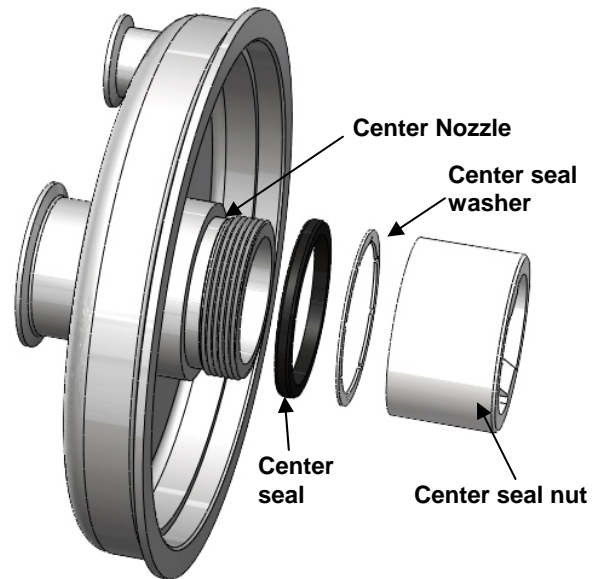

- Lift the end cap and place the center nozzle into the center tube of the cartridge. Check the identification marks to ensure the end cap matches the correct end of the housing.
- Slowly slide the end cap on until it touches the outer O-ring (lumenside). Complete this step for both ends of the contactor.
- Be sure to align the marks placed on the end cap and the housing during disassembly.
- Place the V-Band clamp behind the clamping ridge of the housing. The clamp will need to remain there until the assembly process is complete.
- Repeat these steps for the opposite end of the module.

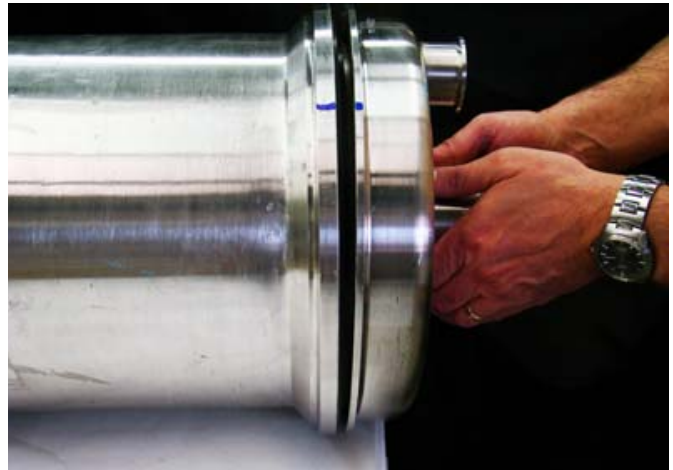

- Carefully place one of the Assembly Brackets on one end cap. Be sure the support knobs, located on the back of the Assembly Bracket, are supporting the bracket on end cap perimeter. Repeat on the opposite end for the other end cap. The brackets should be aligned with each other, perpendicular to the table. **NOTE: The gas nozzle should be in the center of the bracket as shown in the picture below.**



- Insert one section of the Connecting Rods through each of the 4 holes in each bracket.
- Join the rods in the middle using the threaded coupling.
- Insert the smaller rods through the Assembly Bracket holes from the outside and screw into the end of the Connecting Rods. The tightening nuts should be on the outside of the brackets.
- Tighten nuts (two rotations max at a time) to pull the end cap onto the cartridge. Tighten in an even manner that will allow the end cap to progress slowly and evenly. It will be necessary to do the tightening from both ends of the contactor during the installation process.
- Continue checking the alignment marks on the end caps and housing to properly align the end caps.

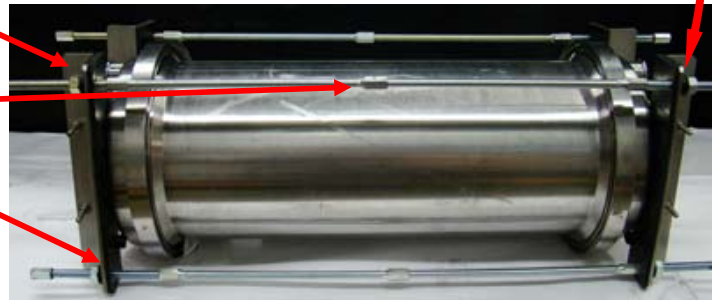

Gas nozzle should be at or near the center of the bracket to reduce the risk of the contactor rolling against the bracket and damaging the nozzle.

- It is necessary to tighten in a pattern similar to the one shown on this picture. This will ensure that the end cap is inserted evenly.
- While the end cap is pulled tight against the housing, place the V-Band clamps on the ridges of housing and the end caps and tighten the clamps.
- Tap around the perimeter of the V-band clamp with a rubber mallet while tightening.
- Loosen and disconnect the connecting rods, then remove the assembly brackets from the housing.



Center Seal Tightening

- Insert the center seal tool into the center nozzle. Turn the tool until you feel the notch in the tool mesh with the nubs of the center nut.
- Using a counter clockwise motion, slowly torque the center seal to 90 ft/lb. (122 Newton/meters). Repeat for other end.



Pressure Test

- Bolt blind flanges on both lumen ports and one of the shell ports.
- Bolt a flange equipped with a 0 - 100 psi gauge and hose connection.
- Pressurize the housing to 60 psig with clean, oil free, air.
- Isolate the pressurized housing and monitor the pressure to verify a leak free seal. There should be no pressure decay over 30 minutes. If there is, you may need to reassemble the O-rings.

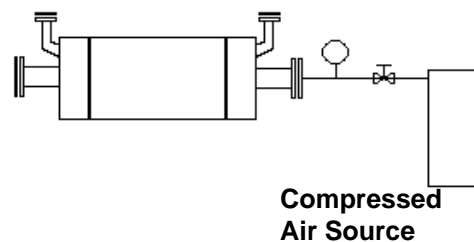



ISO 9001
ISO 14001

This product is to be used only by persons familiar with its use. It must be maintained within the stated limitations. All sales are subject to Seller's terms and conditions. Purchaser assumes all responsibility for the suitability and fitness for use as well as for the protection of the environment and for health and safety involving this product. Seller reserves the right to modify this document without prior notice. Check with your representative to verify the latest update. To the best of our knowledge, the information contained herein is accurate. However, neither Seller nor any of its affiliates assumes any liability whatsoever for the accuracy or completeness of the information contained herein. Determination of the suitability of any material and infringement of any third party rights, including patent, trademark, or copyright rights, are the sole responsibility of the user. Users of any substance should satisfy themselves by independent investigation that the material can be used safely. We may have described certain hazards, but we cannot guarantee that these are the only hazards that exist. Nothing herein shall be construed as a recommendation or license to use any information that conflicts with any patent, trademark or copyright of Seller or others. Please read our Operating Manuals carefully before installing and using these modules.

THE INFORMATION CONTAINED HEREIN AND SELLER'S PRODUCTS ARE PROVIDED "AS IS" WITHOUT WARRANTY ANY KIND, EITHER EXPRESSED OR IMPLIED, INCLUDING, BUT NOT LIMITED TO, THE IMPLIED WARRANTIES OF MERCHANTABILITY, FITNESS FOR ANY PARTICULAR PURPOSE OR USE, OR NON-INFRINGEMENT OF INTELLECTUAL PROPERTY. IN NO EVENT SHALL SELLER BE LIABLE FOR ANY SPECIAL, INCIDENTAL, INDIRECT, OR CONSEQUENTIAL DAMAGES OF ANY KIND, OR ANY DAMAGES WHATSOEVER RESULTING FROM THE USE OF INFORMATION CONTAINED HEREIN AND SELLER'S PRODUCTS.

Liqui-Cel[®], SuperPhobic[®], MiniModule[®], and MicroModule[®] are registered trademarks of Membrana-Charlotte, A Division of Celgard, LLC.

Copyright © 2011 Membrana – Charlotte All rights reserved.

PC-M153 10X28 SS Sanitary Assembly and Disassembly Instructions 6-11.

Membrana - Charlotte

A Division of Celgard, LLC
13800 South Lakes Drive
Charlotte, North Carolina 28273
USA
Phone: 704 587 8888
Fax: 704 587 8610
info@liqui-cel.com

Membrana GmbH

Oehder Strasse 28
42289 Wuppertal
Germany
Phone: +49 202 6099 -658
+49 6126 2260 -41
Fax: +49 202 6099 -750
info@liqui-cel.com

Membrana - Japan

Shinjuku Mitsui Bldg., 27th Floor
1-1, Nishishinjuku 2-Chome
Shinjuku-ku, Tokyo 163-0427
Japan
Phone: 81 3 5324 3361
Fax: 81 3 5324 3369
info@liqui-cel.com



www.membrana.com
www.liqui-cel.com